

ELECTROSTATIC SENSITIVE DEVICE
OBSERVE HANDLING PRECAUTIONS

MITSUBISHI RF POWER MOS FET

RD01MUS2

RoHS Compliance, Silicon MOSFET Power Transistor 520MHz,1W

DESCRIPTION

RD01MUS2 is a MOS FET type transistor specifically designed for VHF/UHF RF amplifiers applications. This device have an interal monolithic zener diode from gate to source for ESD protection.

FEATURES

- High power gain:
Pout>0.8W, Gp>14dB @Vdd=7.2V,f=520MHz
- High Efficiency: 65%typ.
- Integrated gate protection diode

APPLICATION

For output stage of high power amplifiers in VHF/UHF Band mobile radio sets.

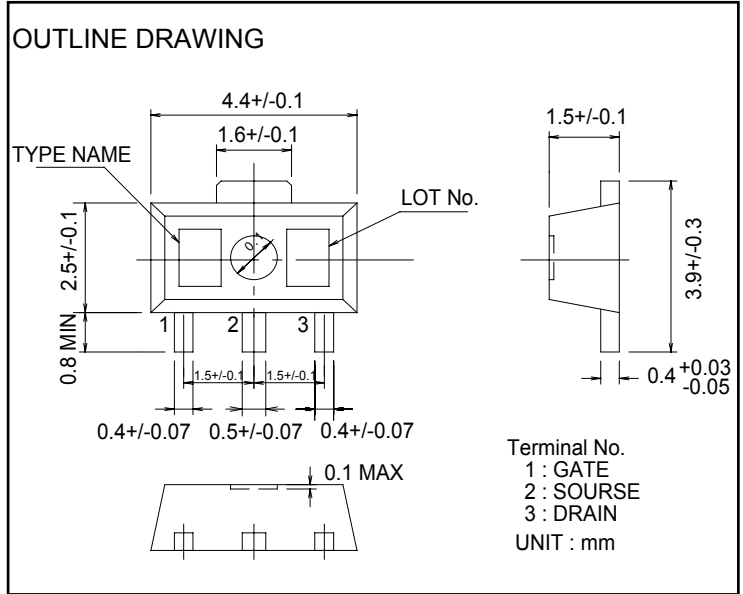

RoHS COMPLIANT

RD01MUS2-101,T113 is a RoHS compliant products.

This product include the lead in high melting temperature type solders. How ever,it applicable to the following exceptions of RoHS Directions.

- 1.Lead in high melting temperature type solders(i.e.tin-lead solder alloys containing more than85% lead.)

ABSOLUTE MAXIMUM RATINGS

(Tc=25°C UNLESS OTHERWISE NOTED)

SYMBOL	PARAMETER	CONDITIONS	RATINGS	UNIT
VDSS	Drain to source voltage	Vgs=0V	30	V
VGSS	Gate to source voltage	Vds=0V	-5/+10	V
Pch	Channel dissipation	Tc=25°C	3.6	W
Pin	Input Power	Zg=Zl=50Ω	60	mW
ID	Drain Current	-	600	mA
Tch	Channel Temperature	-	150	°C
Tstg	Storage temperature	-	-40 to +125	°C
Rth j-c	Thermal resistance	Junction to case	34.5	°C/W

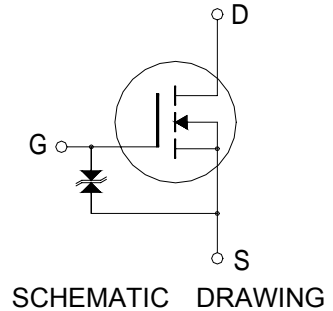

Note 1: Above parameters are guaranteed independently.

ELECTRICAL CHARACTERISTICS

(Tc=25°C, UNLESS OTHERWISE NOTED)

SYMBOL	PARAMETER	CONDITIONS	LIMITS			UNIT
			MIN	TYP	MAX	
Idss	Zero gate voltage drain current	VDS=17V, VGS=0V	-	-	50	uA
Igss	Gate to source leak current	VGS=10V, VDS=0V	-	-	1	uA
Vth	Gate threshold Voltage	VDS=12V, Ids=1mA	1	1.8	3	V
Pout	Output power	VDD=7.2V, Pin=30mW	0.8	1.4	-	W
ηd	Drain efficiency	f=520MHz, Idq=100mA	50	65	-	%

Note : Above parameters , ratings , limits and conditions are subject to change.



ELECTROSTATIC SENSITIVE DEVICE
OBSERVE HANDLING PRECAUTIONS

MITSUBISHI RF POWER MOS FET

RD01MUS2

RoHS Compliance, Silicon MOSFET Power Transistor 520MHz,1W

TYPICAL CHARACTERISTICS

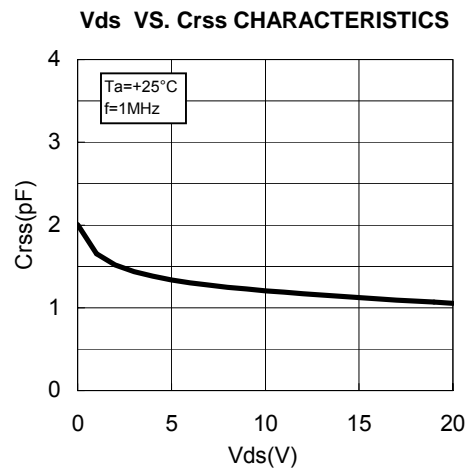
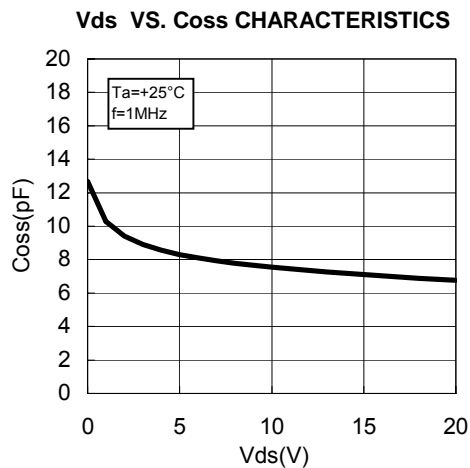
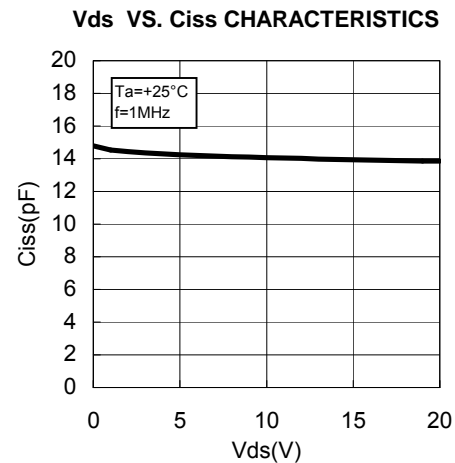
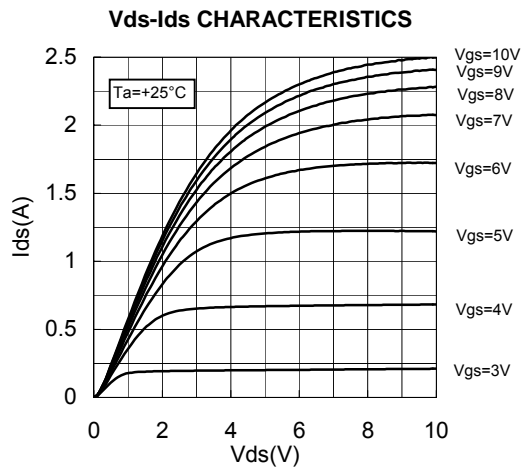
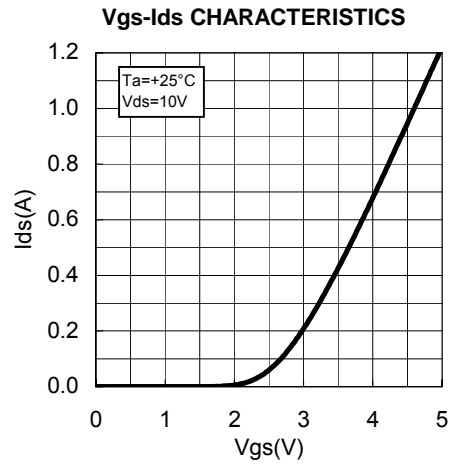
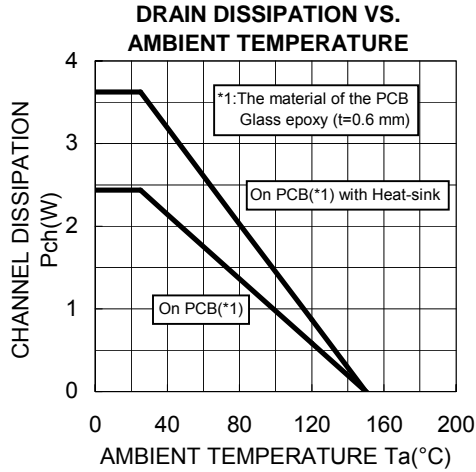

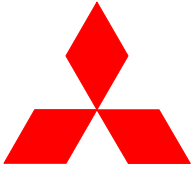

ELECTROSTATIC SENSITIVE DEVICE
OBSERVE HANDLING PRECAUTIONS

MITSUBISHI RF POWER MOS FET

RD01MUS2

RoHS Compliance, Silicon MOSFET Power Transistor 520MHz,1W

TYPICAL CHARACTERISTICS

Pin-Po CHARACTERISTICS

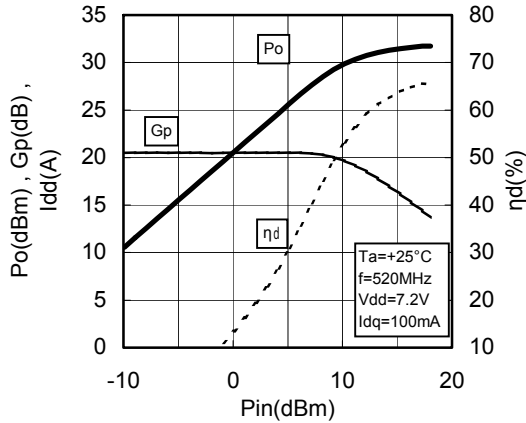

Pin-Po CHARACTERISTICS

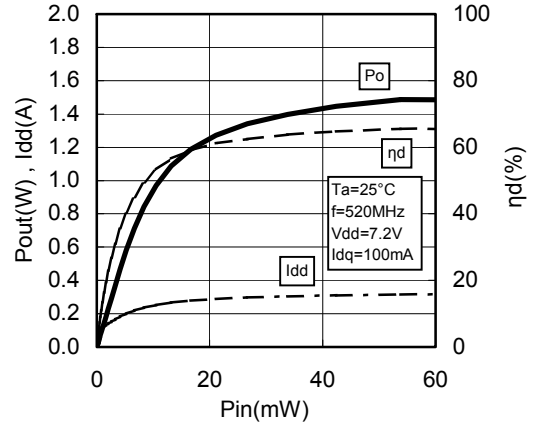

Vdd-Po CHARACTERISTICS

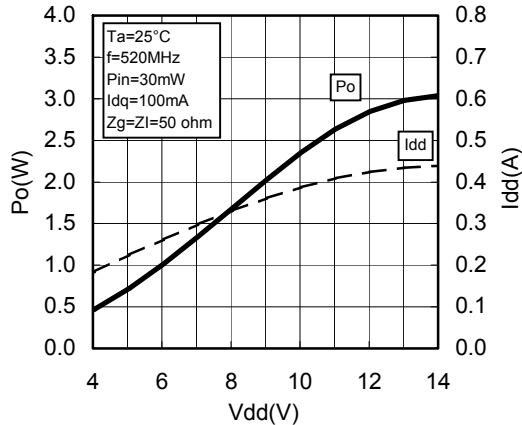

Vgs-Ids CHARACTERISTICS 2

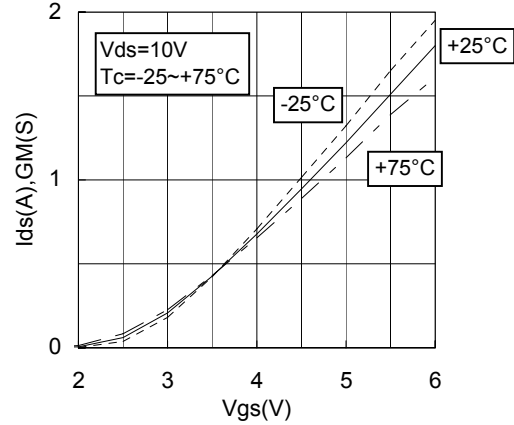

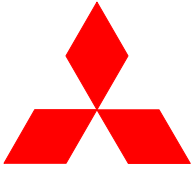

ELECTROSTATIC SENSITIVE DEVICE
OBSERVE HANDLING PRECAUTIONS

MITSUBISHI RF POWER MOS FET

RD01MUS2

RoHS Compliance, Silicon MOSFET Power Transistor 520MHz,1W

TEST CIRCUIT(f=520MHz)

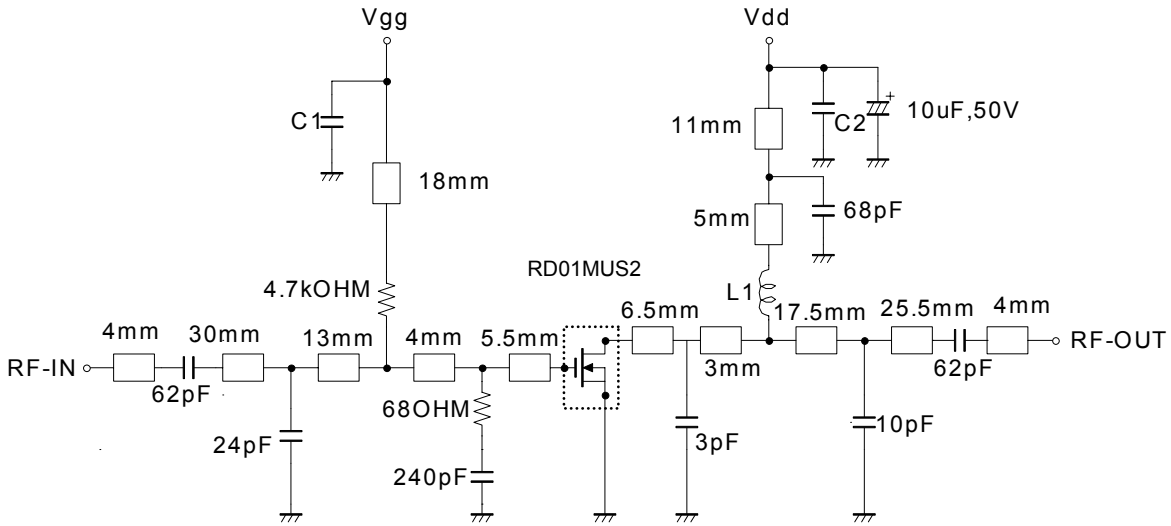

L1: Enameled wire 5Turns,D:0.43mm,2.46mm O.D
C1,C2: 1000pF,0.022uF in parallel

Note:Board material-glass epoxy substrate
Micro strip line width=1.0mm/50OHM,er:4.8,t=0.6mm

INPUT/OUTPUT IMPEDANCE VS. FREQUENCY CHARACTERISTICS

520MHz Z_{in}^* Z_{out}^*
 $Z_o=50\Omega$

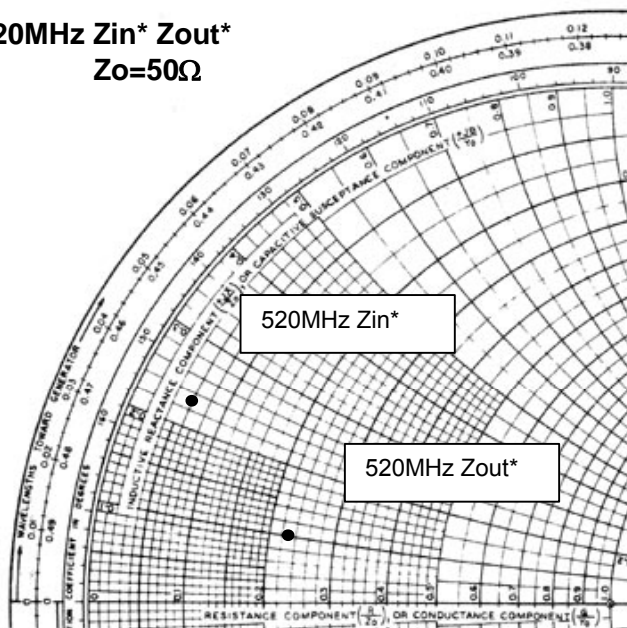

Vdd=7.2V, Idq=100mA(Vgg adj.),Pin=0.03W

$Z_{in}^* = 3.11 + j11.56$
 $Z_{out}^* = 11.64 + j4.74$

Z_{in}^* : Complex conjugate of input impedance
 Z_{out}^* : Complex conjugate of output impedance

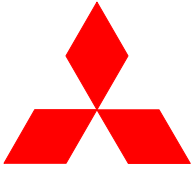

ELECTROSTATIC SENSITIVE DEVICE
OBSERVE HANDLING PRECAUTIONS

MITSUBISHI RF POWER MOS FET

RD01MUS2

RoHS Compliance, Silicon MOSFET Power Transistor 520MHz,1W

RD01MSU2 S-PARAMETER DATA (@Vdd=7.2V, Id=100mA)

Freq. [MHz]	S11		S21		S12		S22	
	(mag)	(ang)	(mag)	(ang)	(mag)	(ang)	(mag)	(ang)
100	0.941	-83.9	18.598	128.5	0.046	36.0	0.761	-65.2
150	0.881	-107.9	14.425	112.0	0.052	21.1	0.660	-85.2
175	0.863	-116.7	12.863	105.7	0.054	15.3	0.632	-92.3
200	0.844	-123.9	11.496	100.2	0.054	10.8	0.606	-98.0
250	0.820	-134.4	9.351	91.4	0.054	3.0	0.575	-107.2
300	0.813	-142.3	7.854	84.1	0.053	-4.3	0.566	-114.1
350	0.807	-148.3	6.682	77.7	0.053	-7.8	0.569	-119.4
400	0.807	-152.7	5.797	72.5	0.051	-12.7	0.574	-123.7
450	0.809	-156.9	5.096	67.0	0.048	-17.1	0.588	-127.7
500	0.810	-160.0	4.487	62.7	0.047	-20.0	0.604	-131.0
520	0.812	-161.2	4.286	61.0	0.046	-21.0	0.609	-132.4
550	0.813	-163.1	3.996	58.1	0.045	-24.7	0.620	-134.3
600	0.820	-165.6	3.595	54.1	0.041	-25.0	0.637	-137.2
650	0.822	-168.0	3.231	50.4	0.040	-29.2	0.653	-139.7
700	0.831	-170.1	2.944	46.8	0.038	-31.4	0.672	-142.4
750	0.837	-172.1	2.686	43.2	0.035	-33.6	0.686	-144.6
800	0.842	-174.0	2.451	40.0	0.033	-35.2	0.703	-147.1
850	0.847	-176.0	2.255	36.6	0.030	-37.7	0.717	-149.3
900	0.853	-177.9	2.076	33.6	0.027	-37.8	0.731	-151.3
950	0.857	-179.6	1.915	30.7	0.025	-37.4	0.742	-153.6
1000	0.862	178.9	1.769	28.0	0.022	-37.8	0.757	-155.5
1050	0.865	177.2	1.645	25.5	0.020	-37.5	0.766	-157.6
1100	0.870	175.6	1.526	23.2	0.017	-34.9	0.778	-159.3

RD01MSU2 S-PARAMETER DATA (@Vdd=12.5V, Id=100mA)

Freq. [MHz]	S11		S21		S12		S22	
	(mag)	(ang)	(mag)	(ang)	(mag)	(ang)	(mag)	(ang)
100	0.957	-79.3	18.576	131.4	0.041	40.9	0.740	-59.4
150	0.902	-103.4	14.762	114.9	0.049	24.5	0.642	-78.6
175	0.884	-112.7	13.236	108.3	0.049	17.9	0.615	-85.4
200	0.867	-120.1	11.888	102.6	0.051	13.0	0.592	-91.3
250	0.843	-131.4	9.751	93.5	0.051	6.1	0.559	-100.5
300	0.831	-139.8	8.210	86.0	0.050	-1.5	0.553	-107.6
350	0.824	-146.1	7.005	79.5	0.050	-6.4	0.553	-112.9
400	0.821	-150.9	6.079	74.1	0.048	-11.2	0.559	-117.9
450	0.823	-155.3	5.343	68.6	0.046	-14.5	0.573	-122.0
500	0.824	-158.6	4.726	64.2	0.043	-19.2	0.589	-125.5
520	0.826	-160.0	4.523	62.2	0.044	-19.3	0.594	-127.1
550	0.825	-161.9	4.226	59.6	0.042	-21.9	0.605	-129.0
600	0.829	-164.4	3.792	55.6	0.040	-23.9	0.622	-132.0
650	0.833	-167.2	3.429	51.5	0.037	-27.8	0.639	-134.9
700	0.839	-169.4	3.117	47.7	0.035	-30.5	0.656	-137.8
750	0.843	-171.5	2.837	44.2	0.033	-31.2	0.675	-140.1
800	0.849	-173.6	2.597	41.1	0.030	-34.9	0.691	-143.0
850	0.854	-175.4	2.397	37.6	0.028	-35.3	0.705	-145.2
900	0.858	-177.2	2.196	34.7	0.026	-35.7	0.718	-147.6
950	0.862	-179.0	2.034	31.8	0.022	-37.5	0.732	-149.6
1000	0.869	179.4	1.890	29.0	0.020	-37.4	0.745	-151.9
1050	0.870	177.6	1.745	26.2	0.018	-37.7	0.757	-154.1
1100	0.876	175.9	1.625	23.4	0.017	-33.9	0.770	-156.0



ELECTROSTATIC SENSITIVE DEVICE
OBSERVE HANDLING PRECAUTIONS

mitsubishi RF POWER MOS FET

RD01MUS2

RoHS Compliance, Silicon MOSFET Power Transistor 520MHz,1W

Keep safety first in your circuit designs!

Mitsubishi Electric Corporation puts the maximum effort into making semiconductor products better and more reliable, but there is always the possibility that trouble may occur with them. Trouble with semiconductors may lead to personal injury, fire or property damage. Remember to give due consideration to safety when making your circuit designs, with appropriate measures such as (i) placement of substitutive, auxiliary circuits, (ii) use of non-flammable material or (iii) prevention against any malfunction or mishap.

warning !

Do not use the device at the exceeded the maximum rating condition. In case of plastic molded devices, the exceeded maximum rating condition may cause blowout, smoldering or catch fire of the molding resin due to extreme short current flow between the drain and the source of the device. These results causes in fire or injury.